



Quadro User Manual

Table of Contents

- 1. Quick Reference 4
- 2. Introduction 5
 - 1.1 What is Quadro 6
 - 1.2 Components and Features 7
 - 1.3 Qualification Status 7
 - 1.4 Deployment Sequence 9
- 3. System Description 10
 - 2.1 Coordinate System 11
 - 2.2 Mass Properties 12
 - 2.3 Mounting Configurations 13
 - 2.4 Mechanical Interfaces..... 13
 - 2.5 Keep-Out Dimensions 13
 - 2.6 Maximum Loads..... 14
 - 2.7 Stiffness and FEM Modeling..... 14
 - 2.8 Deployment Velocity 15
 - 2.9 Tip-Off Rates 16
 - 2.11 Electrical Properties 17
 - 2.11.1 DSub-9 Connectors..... 17
 - 2.11.2 Separation Signal 18
 - 2.11.3 Quadro Accessories 18
 - 2.11.4 Grounding 19
 - 2.12 Thermal Properties 19
- 4. Installation and Operation..... 20
 - 3.1 Installation 21
 - 3.1.1 Preparation 21
 - 3.1.2 Alignment 23
 - 3.1.3 Installation..... 26
 - 3.1.4 Functional Test and Reset 28
- 5. Mechanical Interfaces..... 30
 - 6.A.1. Quadro Arrow 150 Satellite Interface..... 31
 - 7.A.2. Quadro Arrow 150 Launch Vehicle Interface 32

Version	Author	Date	Changes
1.0	CP	February 2, 2024	Initial release.
1.1	CP	June 26, 2024	Updated strength and stiffness values, thermal properties, S-adapter color. Removed additional Quadro configurations.
1.2	CP	June 28, 2024	Removed stiffness values, added Quadro FEM details
2.0	MF	08 August, 2024	Removed Bending Moment Limit. Value is still TBD. Updated SV-side interface drawing.

Quick Reference

Figure 1:
Quadro Coordinate System.

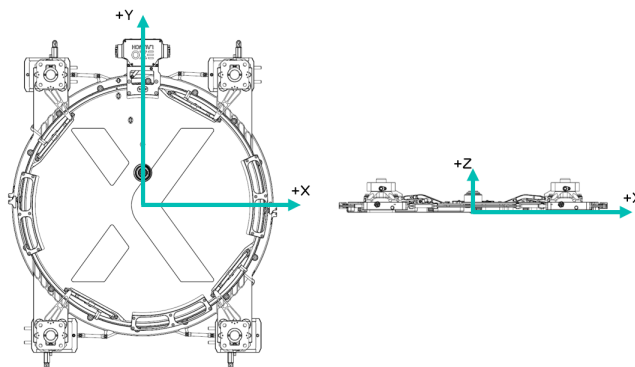

Table 1: Quadro Characteristics Overview.

Parameter		Section	Arrow 150
Mounting Pattern	HDRM Spacing (X) [mm]	2.4	456
	HDRM Spacing (Y) [mm]		645
	HDRM Spacing (X) [in]		17.953
	HDRM Spacing (Y) [in]		25.394
	Number of Fasteners		16
	Fastener Type		M8
	Flatness Tolerance [mm]		0.1
Keep-Out Dimensions [mm]	Inner keep-out diameter [mm]	2.5	500
	Outer keep-out short edge [mm]		720
	Outer keep-out long edge [mm]		775
Mass [kg]	S-Adapter [kg]	2.2	1.58
	L-Adapter [kg]		6.82
	Combined Mass [kg]		8.40
Maximum Load per HDRM [N]	Axial [kN]	2.6	±75
	Lateral (Shear) [kN]		±20
	Bending [Nm]		TBD
Separation	Nominal Separation Signal	2.11	24VDC for 0.5s
	Average Separation Time [s]		0.1
Thermal [°C]	Lower Operating Limit	2.12	-34
	Upper Operating Limit		+71
	Lower Survival Limit		-55
	Upper Survival Limit		+130



Introduction

1.1 What is Quadro

Quadro follows in the footsteps of Exolaunch's CarboNIX line of microsat separation systems. It is a four-point satellite separation system suitable for satellites weighing up to 300 kg flying on Falcon 9 Rideshare plates. It has been designed for a very wide range of microsatellite buses, including Airbus Arrow 150.



- › **LOW MASS**
Optimized for mass, Quadro offers the lowest flyaway mass of any four-point system.
- › **SHOCK-FREE DEPLOYMENT**
No pyrotechnics ensures that even the most sensitive payloads remain intact after deployment.
- › **LOW TUMBLING**
The patented CarboNIX pusher arm system has an average tip-off rate of 0.6 deg/s in all three axes.
- › **FAST RESET TIME**
Simple but robust magnetic locks are easy to operate and quick to reset.
- › **FLIGHT HERITAGE**
Critical subsystems like lock mechanism and pusher arms have flight heritage across dozens of missions.
- › **ITAR-FREE**
Quadro is not subject to export restrictions of any kind.

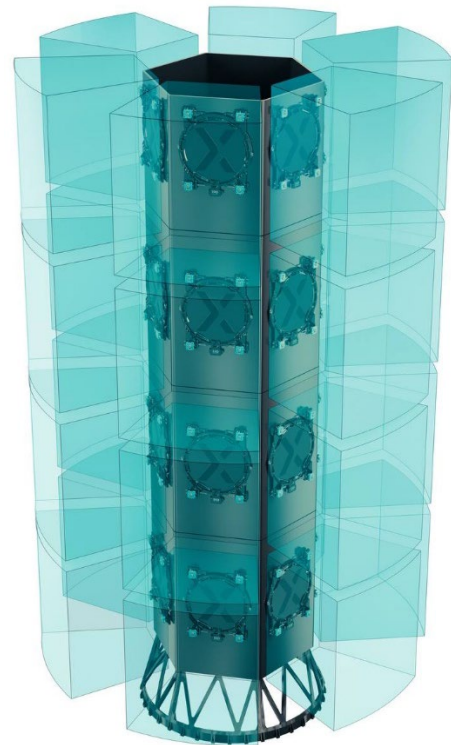

Quadro is suitable for microsatellites between 150kg and 800kg, with this Arrow 150 configuration specifically designed to deploy spacecraft utilizing the Airbus Arrow 150 satellite bus. From the ground up, it has been designed to simplify every step of your satellite mission.

- › Fully mechanically actuated. No need for multiple synchronized deploy signals or signal multiplexers to actuate the four points.
- › Quickly and easily resettable, making it possible to perform integrated functional testing with your satellite in the launch configuration for maximum reliability.
- › Minimal profile. Quadro only occupies four small points on the satellite base plate, the rest is reserved for your spacecraft systems and instruments.
- › Low cost, fast lead time, and no export restrictions.

1.2 Components and Features

The major elements of the Quadro Arrow 150 system are shown below.

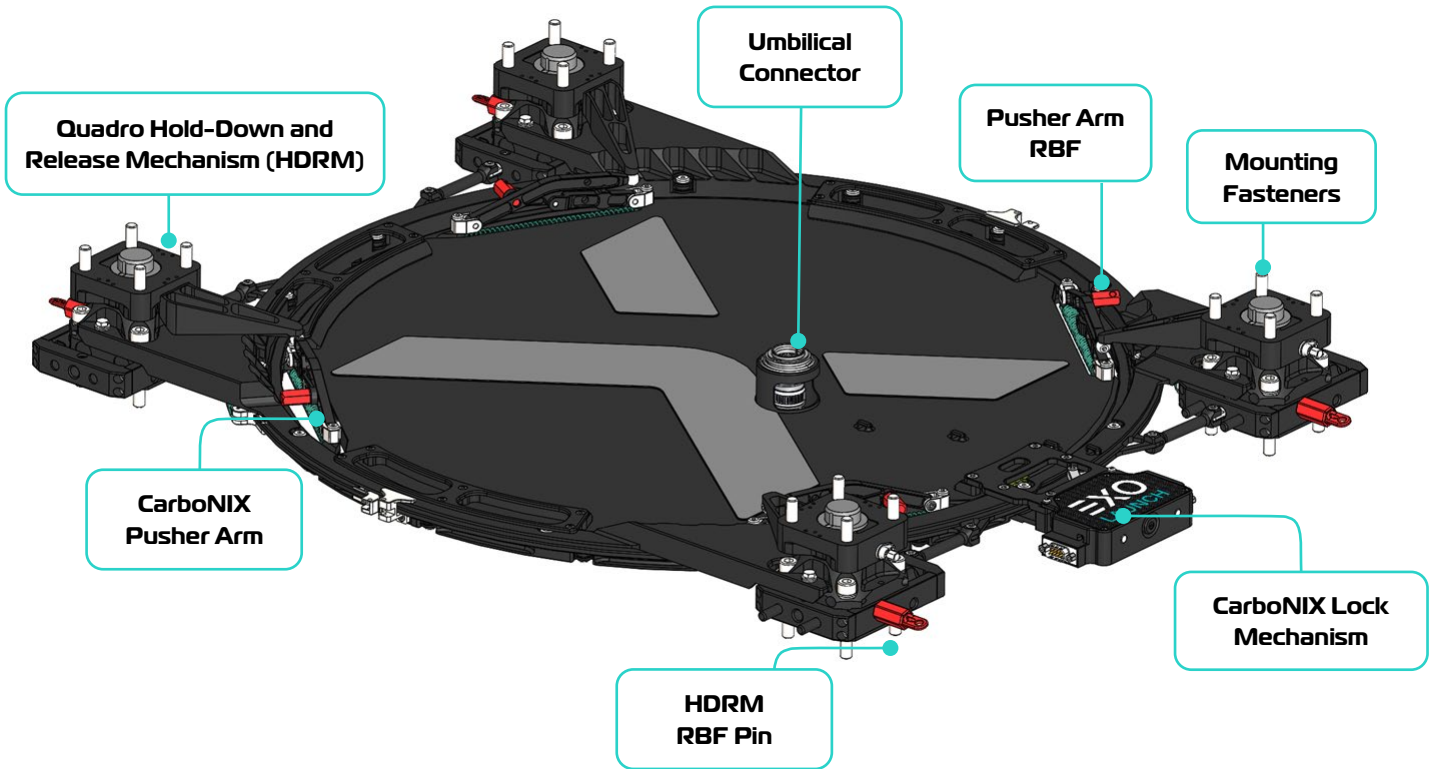

Figure 2: Quadro components overview.

1.3 Qualification Status

Quadro has been tested extensively following Exolaunch testing philosophy and requirements from various launch vehicle producers, primarily SpaceX. In every test, Quadro has demonstrated outstanding reliability and robustness. The Quadro has been demonstrated to be the stiffest four-point system for microsatellites on the market today.

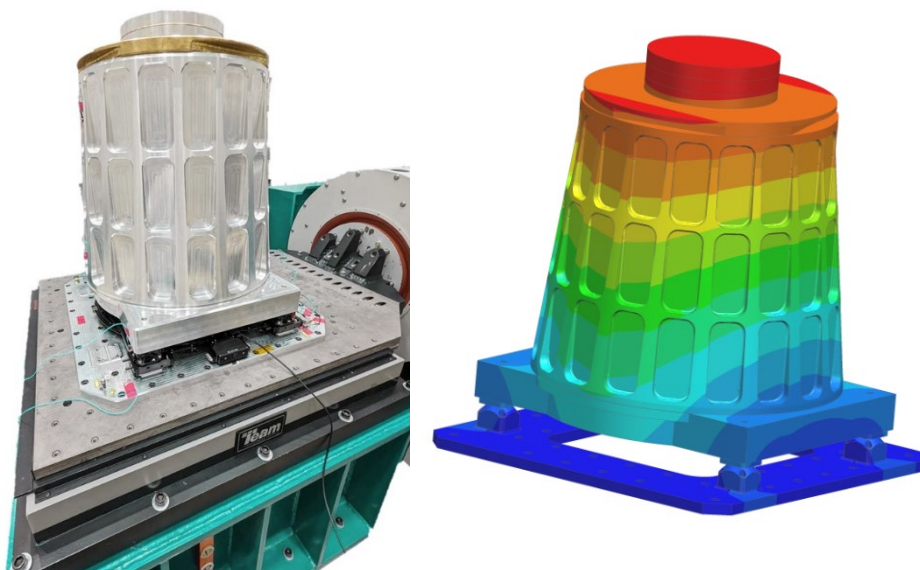

Figure 3: Quadro HDRM Vibration Qualification (left) and Correlation (right)

Exolaunch pushes the limits of testing with every Exolaunch separation system, and Quadro is no exception. The Quadro HDRMs have been tested and pushed to the breaking point so that we know exactly when, where and why our systems fail. This test methodology gives us an unmatched understanding of our systems for an unbeatable reliability.

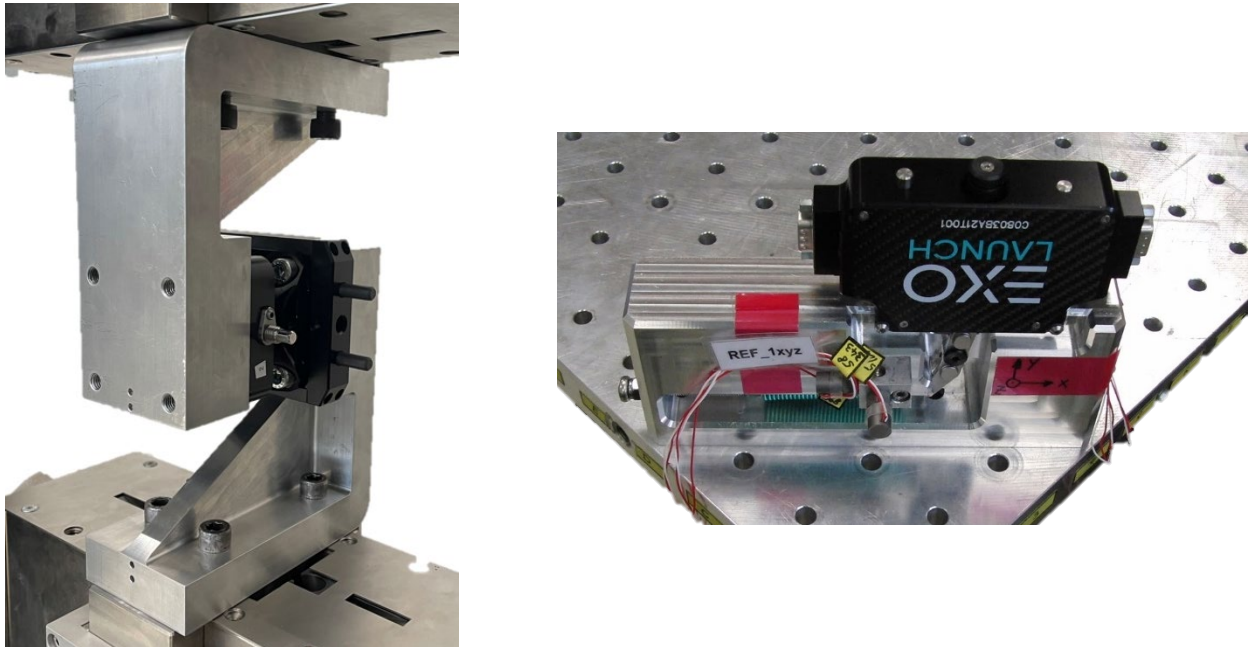

Figure 4: Quadro HDRM Strength Qualification (left) and Shock Qualification (right)

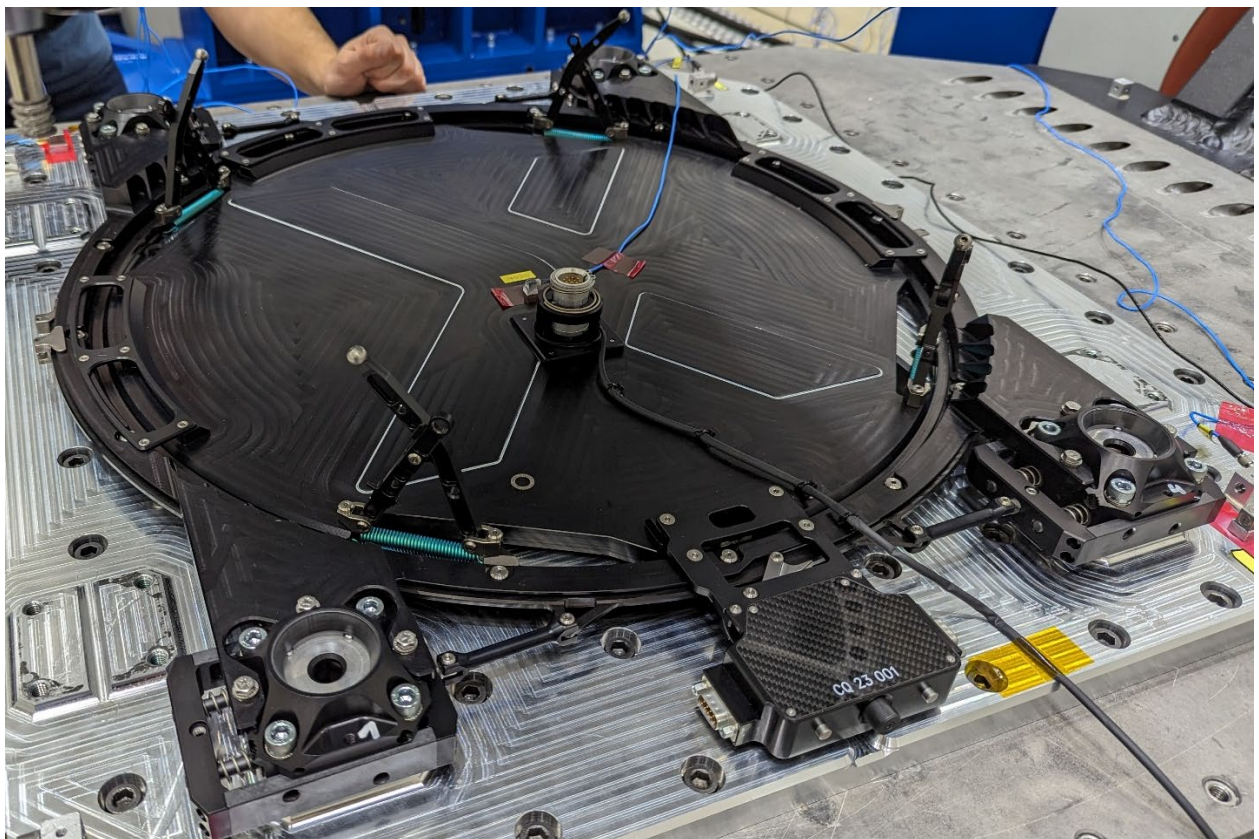

Figure 5: Quadro system under test.

1.4 Deployment Sequence

1. The deploy command opens the redundant magnetic locks, and the inhibit pin is released.
2. Now free to rotate, the synchronization ring drives the deploy arms, opening all four HDRM points simultaneously. The synchronized release is entirely mechanical, and a single deploy command is sufficient to open all four points.
3. With the HDRMs open, the satellite is no longer held to the launch vehicle. The pusher arm system provides the separation velocity for a smooth, stable deployment.
4. Internal telemetry switches toggle when the synchronization ring has rotated and when the pusher arm system is fully extended. The launch vehicle reads these signals through the same DSub-9 connector used to provide the deploy command.

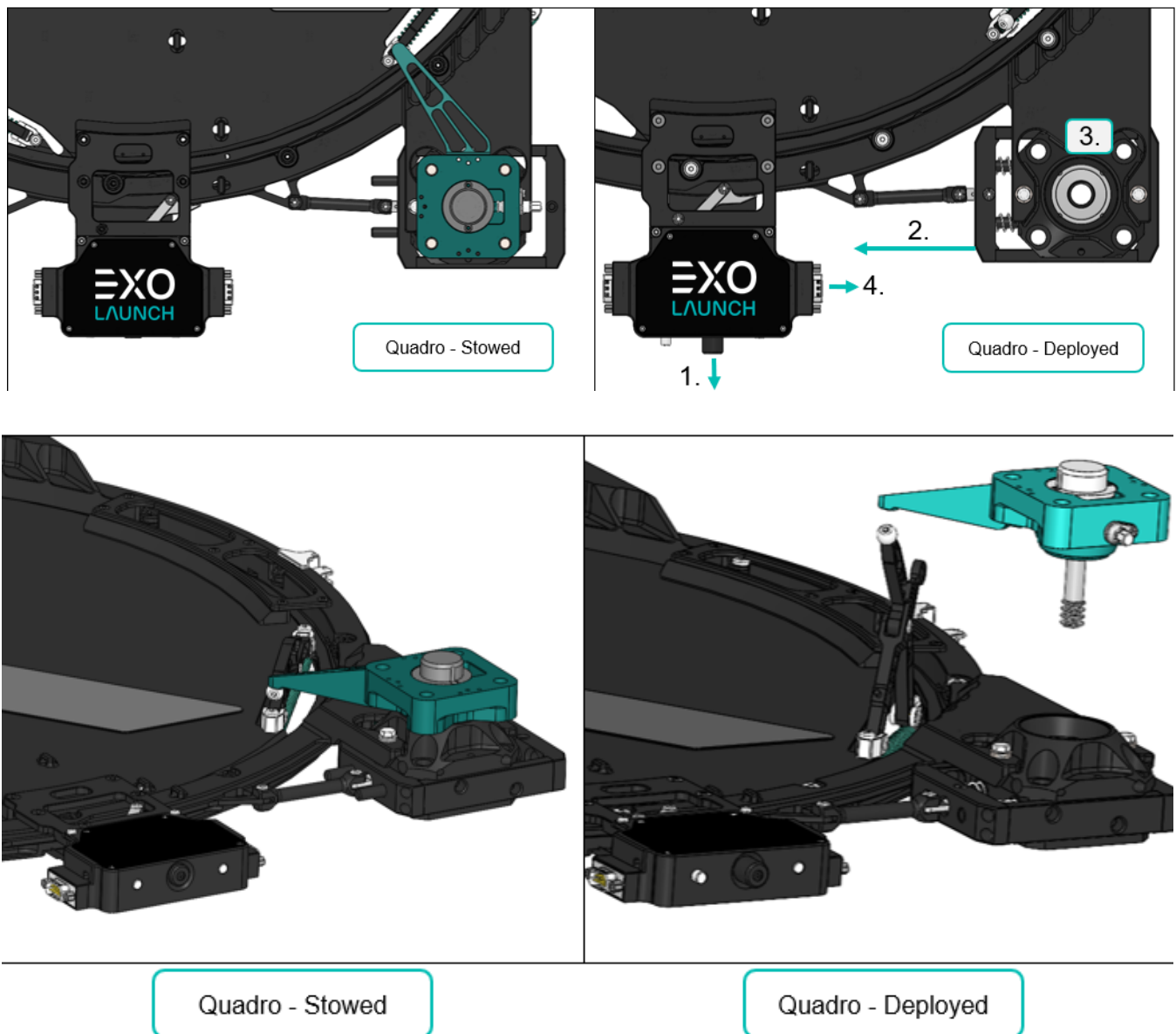
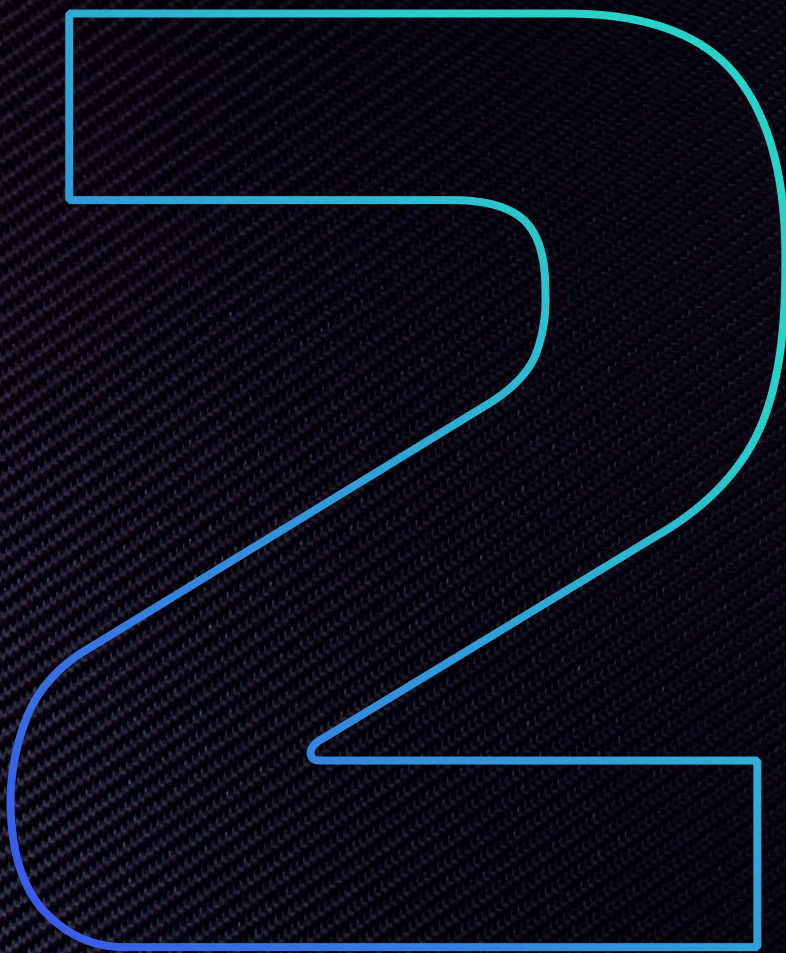

Figure 6: Quadro step-by-step deploy sequence.



System Description

2.1 Coordinate System

The Quadro coordinate system is defined in the same manner for all configurations. The image below illustrates the coordinate system for Quadro configurations both with and without the internal separation connector plate.

The Z-Axis is parallel to the deployment direction and concentric to the synchronization ring, with +Z pointing towards the satellite. The origin of the coordinate system is where the Z-Axis intersects the L-adapter mounting plane. The +Y direction points towards the lock mechanism and is aligned with the footprint of the four point interface. The X-Axis is defined by the right hand rule.

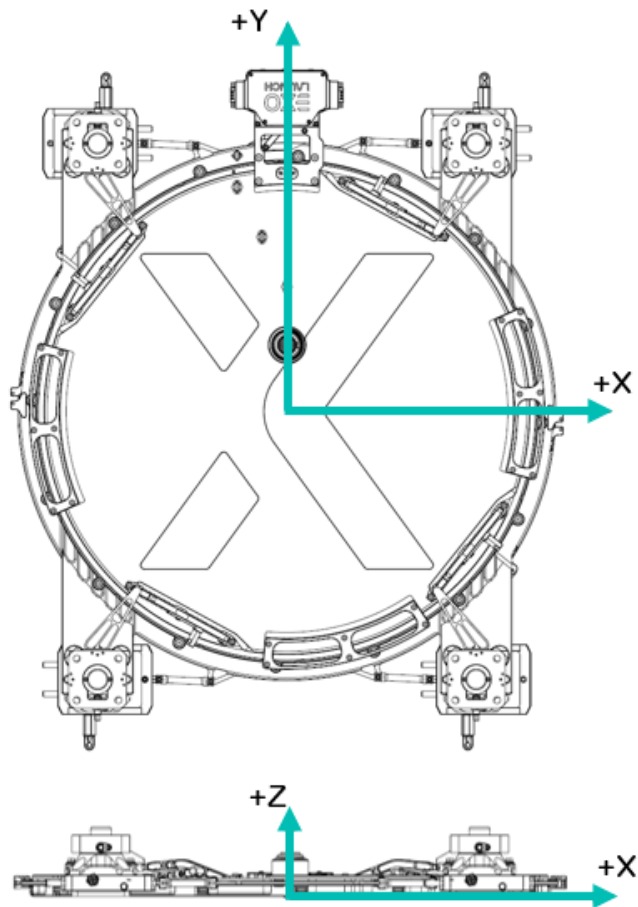

Figure 7: Quadro Coordinate System

2.2 Mass Properties

Mass properties are given here for the Arrow 150 configuration of Quadro, including the center plate and lower separation connector.

Table 2: Quadro Arrow 150 Mass Properties

Configuration		Arrow 150	
S-Adapter Mass (all four points) [kg]		1.58	
L-Adapter Mass [kg]		6.82	
Combined Stowed Mass [kg]		8.40	
S-Adapter	Center of Gravity [mm]	X	0.00
		Y	0.00
		Z	58.38
	Moment of Inertia [kgmm ²]	X	162380.63
		Y	82297.73
		Z	244096.58
	Product of Inertia [kgmm ²]	YZ	0.00
		XZ	0.00
		XY	-22.01
L-Adapter Stowed	Center of Gravity [mm]	X	0.73
		Y	20.78
		Z	17.02
	Moment of Inertia [kgmm ²]	X	456733.19
		Y	279391.66
		Z	734508.88
	Product of Inertia [kgmm ²]	YZ	-247.99
		XZ	8.29
		XY	-5323.11
L-Adapter Deployed	Center of Gravity [mm]	X	0.77
		Y	20.82
		Z	18.18
	Moment of Inertia [kgmm ²]	X	457853.14
		Y	279441.92
		Z	734837.94
	Product of Inertia [kgmm ²]	YZ	-413.35
		XZ	2.20
		XY	-1782.43
Combined System Stowed	Center of Gravity [mm]	X	0.59
		Y	16.86
		Z	24.82
	Moment of Inertia [kgmm ²]	X	621871.69
		Y	363892.17
		Z	979161.92
	Product of Inertia [kgmm ²]	YZ	-1354.28
		XZ	-30.55
		XY	-5325.61

2.3 Mounting Configurations

Quadro can be mated with the launch vehicle and the satellite at each HDRM in the following way. **Note:** Fastener length is dependent on launch adapter and spacecraft hole definition.

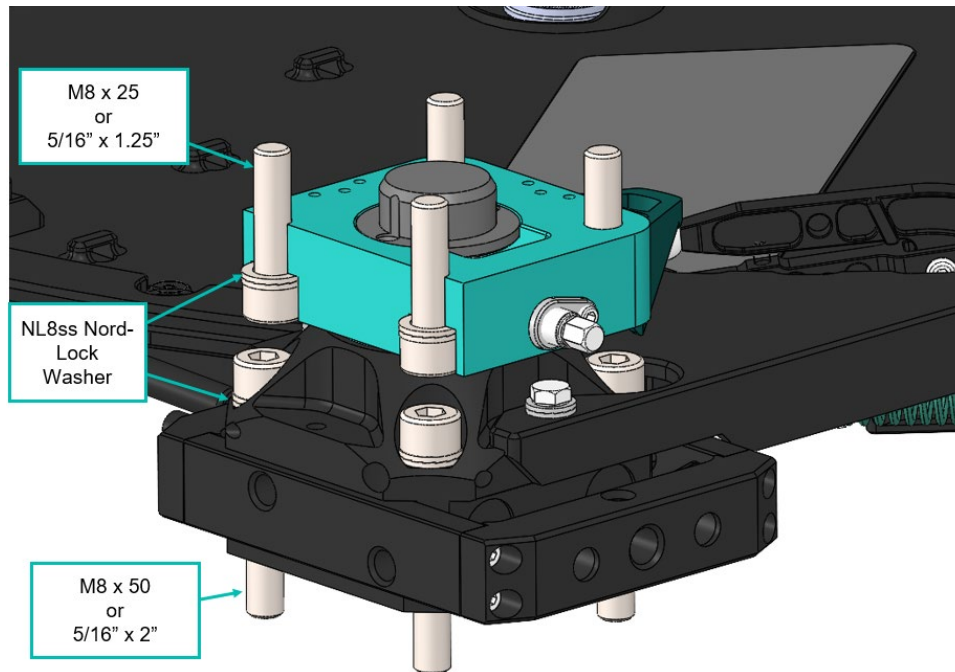

Figure 8: Quadro Mounting Configuration

2.4 Mechanical Interfaces

The mechanical interface definition is dependent on configuration. Detailed mechanical interface definitions can be found in Appendix A3.1.4A. Exolaunch requires customers to provide measurement reports of the satellite-side interface to verify adherence to the defined measurements, tolerances, and other Exolaunch interface requirements.

2.5 Keep-Out Dimensions

The spacecraft and launch vehicle must not interfere with the function of the Quadro mechanisms. In order to verify that Quadro does not intersect the spacecraft, launch vehicle, and ground operations, a dedicated review of these operations should be conducted with CAD files supplied by Exolaunch. Contact Exolaunch to receive CAD for fit check purposes.

2.6 Maximum Loads

The maximum payload mass capable of being launched by Quadro is determined by the launch vehicle loads and the satellite response to them. It is the customer's responsibility to verify that the loads experienced by the Quadro HDRMs does not exceed the maximum allowable.

Table 3: Quadro Arrow 150 HDRM Maximum Loads

Quadro Arrow 150 HDRM Maximum Loads	
Configuration	Arrow 150
Maximum Axial Force [kN]	±75
Maximum Shear Force [kN]	±20
Bending Moment [Nm]	TBD

2.7 Stiffness and FEM Modeling

The Quadro dynamic behavior is exceptionally stiff. Stiffness has been measured using multiple methods, including direct measurement by measuring deformation under static load and dynamic correlation from vibration test results. Exolaunch can provide a correlated FEM in .bdf format for use with NASTRAN solvers. Four HDRM FEMs should be mounted at the appropriate satellite interface using bolted connections. Contact Exolaunch to receive the Quadro FEM.

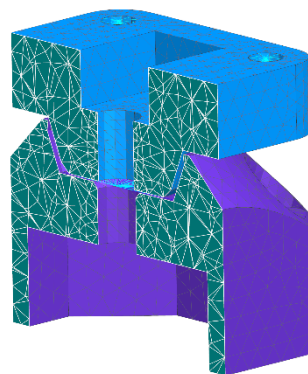

Figure 9: Quadro HDRM Finite Element Model

2.8 Deployment Velocity

Separation velocity depends on the spacecraft mass and the strength of the separation springs. The spring strength can be tailored to match a desired deployment velocity by mixing and matching from the available spring strengths. Using springs of different strengths has no effect on the tip-off rate. Figure 10 demonstrates the relationship between satellite mass and deployment speed relative to different values of the total spring energy.

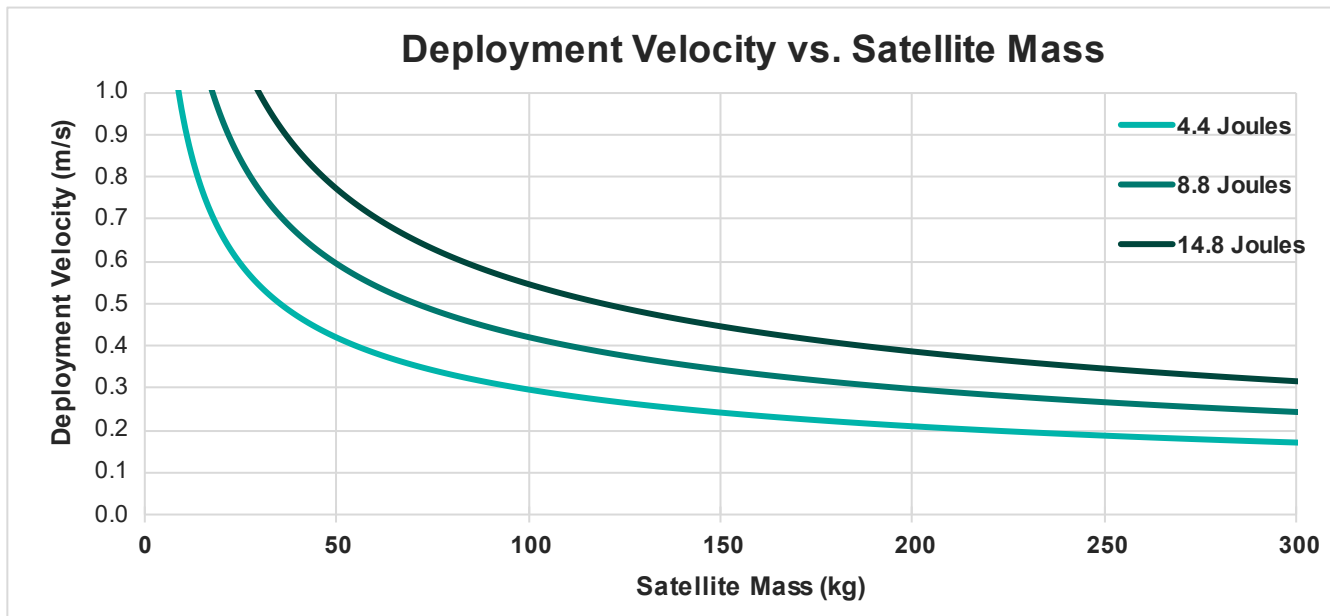

Figure 10: Quadro Separation Velocity

The spring sets have a total energy tolerance of about 10%. Precise spring strengths will be measured in the course of the mission, increasing the precision to 2%. Table 4 shows the minimum and maximum values of the separation energy for each of the four springs. Mixing and matching springs is allowed. For separation velocity calculations, the equation for kinetic energy can be used.

$$KE = \frac{1}{2}mv^2$$

Table 4: Spring Set to Minimum and Maximum Energy

Configuration	Airbus Arrow 150
Number of springs	4
Spring 1 energy (brown) [J]	1.1
Spring 2 energy (black) [J]	2.2
Spring 3 energy (green) [J]	3.7

2.9 Tip-Off Rates

Quadro uses the same pusher-arm system for deployment as the popular Exolaunch CarboNIX microsatellite separation system. Due to the unique design of this system, all four pusher arms will extend at the same speed, regardless of the loads each individual arm faces. For this reason, the satellite will separate with near-zero initial rotation, independent of the satellite mass distribution.

Results from satellites deployed in space show an average rotation rate of 0.6 deg/s across all three axes. No axis rotation higher than 2 deg/s has been recorded from satellites deployed by CarboNIX.

Table 5: Examples of customer-reported tip-off rates for different satellites types.

No.	Satellite Mass [kg]	CG RSS Eccentricity [mm]	Spring Energy (J)	Deploy Velocity [m/s]	CarboNIX Tip-Off Rate [deg/s]			
					X	Y	Z	ABS MAX
1	110	5	4.4	0.28	-0.40	1.09	-0.54	1.09
2	110	5	15.5	0.53	0.13	0.34	0.04	0.34
3	110	5	9.4	0.41	0.25	0.40	1.90	1.9
4	99.7	11	15.5	0.56	0.28	-0.59	0.97	0.97
5	104.4	26.7	15.5	0.54	0.12	1.97	0.65	1.97
6	89.6	28	9.4	0.46	-0.60	-1.01	0.98	1.01
7	116.7	16.1	15.5	0.52	0.97	0.12	2.20	2.2
8	90.9	24.1	15.5	0.58	1.47	0.61	-0.77	1.47
9	91.7	36.1	9.4	0.45	-0.59	-0.41	-0.37	0.59
10	90.8	28	15.5	0.58	1.02	-0.83	0.51	1.02
11	89.9	35.7	15.5	0.59	0.27	0.03	0.79	0.79
12	108.8	15.7	15.5	0.53	0.05	1.39	1.34	1.39
13	110	5	4.4	0.28	0.50	0.50	0.90	0.9
14	89.6	28	10.4	0.48	-0.70	-0.49	0.80	0.8
15	105	26.7	15.5	0.54	0.02	1.80	2.22	2.22
16	91.4	34.3	15.5	0.58	1.45	0.25	-0.23	1.45
17	110	5	15.5	0.53	-0.29	-0.10	-0.26	0.29
18	110	5	9.4	0.41	-0.31	-0.28	-0.78	0.78
19	90.4	22.7	15.5	0.59	-0.80	-0.25	0.13	0.8
20	88.7	13.7	9.4	0.46	0.03	0.70	0.54	0.7
21	89.3	28	13.9	0.56	0.48	0.49	0.61	0.61
22	96.1	12.8	13.9	0.54	-0.80	0.59	1.89	1.89
23	21.9	6.6	4.4	0.63	1.38	0.73	1.21	1.38
Max tip-off rate (deg/s)								2.22

2.11 Electrical Properties

2.11.1 DSub-9 Connectors

The Quadro locking mechanism has two male DSub-9 connectors (Harting 09674095615). Each connector is identical, and either one or both connectors can be used to trigger CarboNIX.

Figure 11:
Illustration of the Two
DSub-9 Connectors

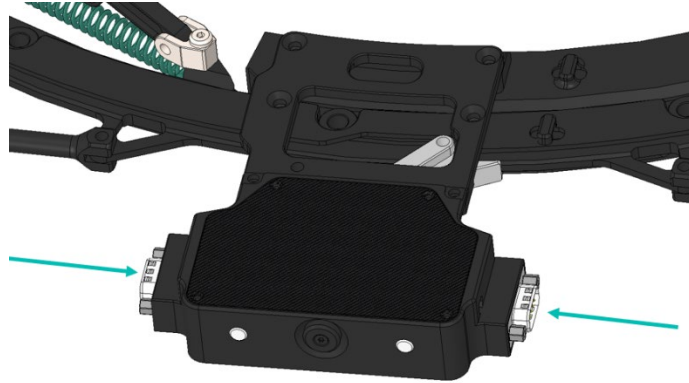
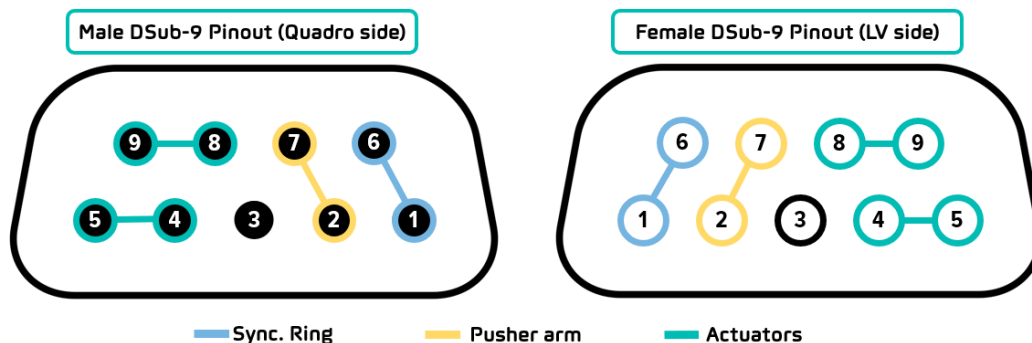

Table 6: Quadro Pinout

Pin	Designation	Function	Continuity Check Across Pins
1	Clamp Ring TM1	Closed after deployment	
2	Pusher Arm TM2	Closed after deployment	
3	-	-	
4	Actuator 2	Return	1.2V ± 10% drop across pins, using multimeter* in Diode mode.
5	Actuator 2	VCC	
6	Clamp Ring TM1	Closed after deployment	
7	Pusher Arm TM2	Closed after deployment	
8	Actuator 1	Return	1.2V ± 10% drop across pins, using multimeter* in Diode mode.
9	Actuator 1	VCC	

*Explosion-safe multimeter not required.



2.11.2 Separation Signal

CarboNIX uses two permanent electromagnets at the heart of the locking mechanism. Similar to a solenoid, these devices use a permanent magnet to hold CarboNIX locked in place, without power, until the separation signal is received.

Holding force [N]	70	Minimum All-fire Current [mA]	160
Voltage Drop	1.2V ± 5%	Nominal Separation Current [mA]	280
Nominal Voltage [V]	28	Maximum Current [mA]	500
Voltage Range [V]	24-36	Nominal Pulse Duration [ms]	500
Maximum No-fire Current [mA]	25	Duty Cycle (cycle time 30s)	10%

Table 7: Permanent Electromagnet Properties

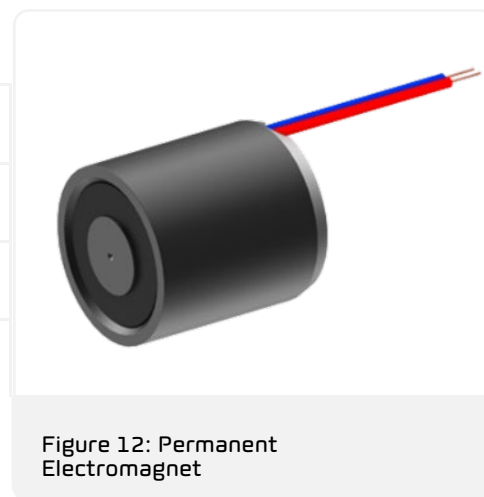
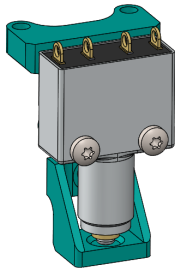
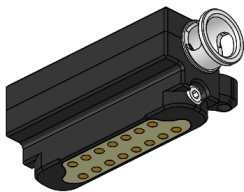
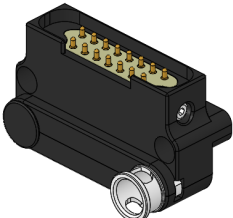

Figure 12: Permanent Electromagnet

2.11.3 Quadro Accessories

Quadro uses the same accessories as CarboNIX. Switches are used by the satellite to detect deployment from the launch vehicle, while separation connectors enable the use of umbilical lines to the launch vehicle.

Table 8: Quadro Accessory Mass

Separation Switch (incl. mounting bracket and plunger receptacle) [g]	20.0	
Upper Separation Connector [g]	11.4	
Lower Separation Connector [g]	14.6	

2.11.4 Grounding

CarboNIX provides an electrically conductive path from the satellite interface to the launch vehicle, eliminating the need for dedicated grounding straps. The satellite manufacturer is responsible for ensuring that the Quadro mounting fasteners are electrically connected to the rest of the satellite structure.

2.12 Thermal Properties

For thermal modeling exercises, the following measured thermal properties of the Quadro system can be used.

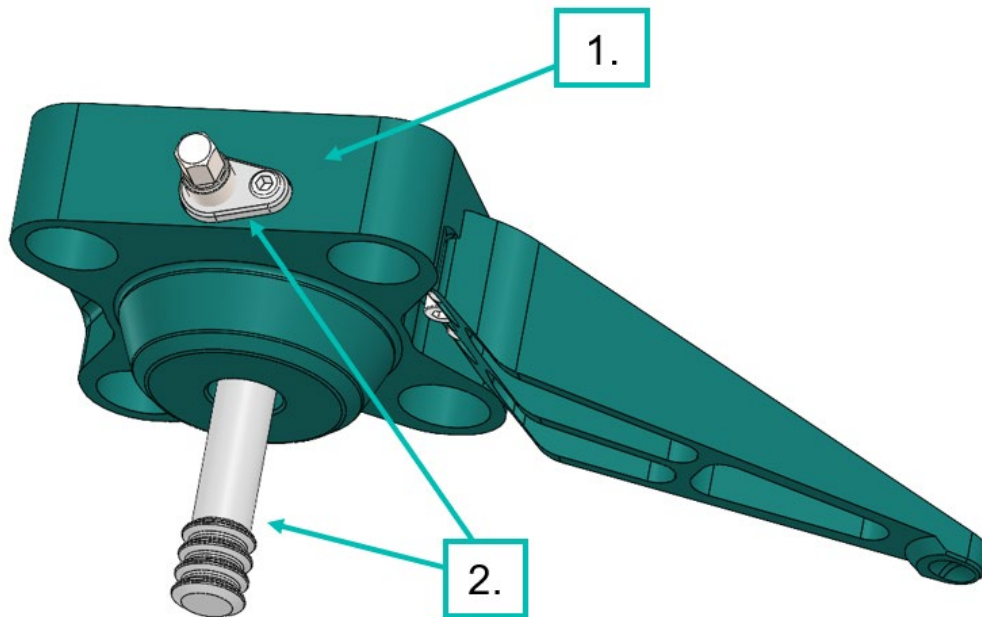

Figure 13: Quadro S-Adapter Materials

Table 9: Quadro S-Adapter Thermal Properties

No.	Color	Emissivity	Absorptivity
1	Green	0.85	0.58
2	Silver	0.11	0.42



Installation and Operation

3.1 Installation

3.1.1 Preparation

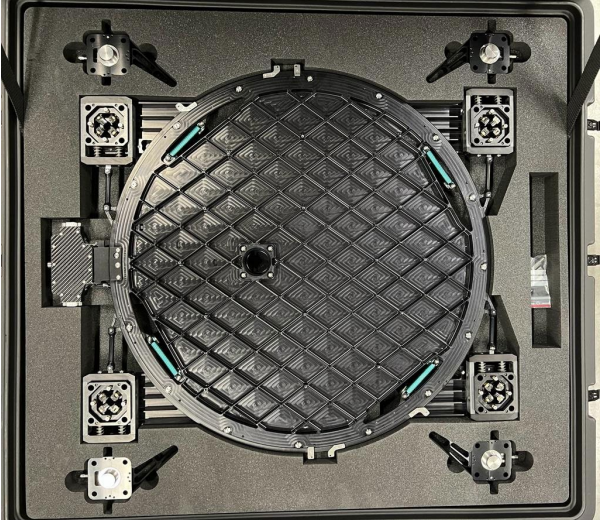
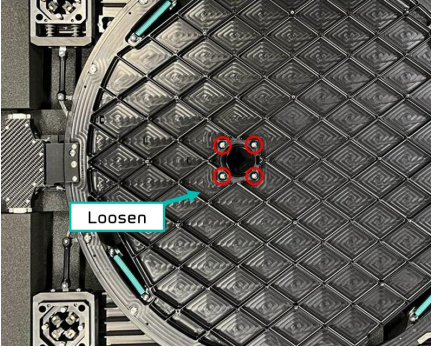
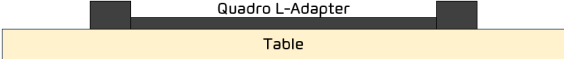
<p>1.</p>	<p>Initial condition: Quadro is stored in a low-energy state, with all springs in their relaxed position.</p> <ul style="list-style-type: none"> • Pusher arms are extended • HDRMs are disengaged • The lock mechanism is open • All RBF elements are removed 	
<p>2.</p>	<p>Inspect the system to ensure there is no damage or contamination.</p>	
<p>3.</p>	<p>Loosen the four mounting screws holding the Sep-Connector to the Quadro base ring.</p>	
<p>4.</p>	<p>Place the L-adapter on a stiff, flat, and clean surface capable of holding the weight of the spacecraft.</p>	

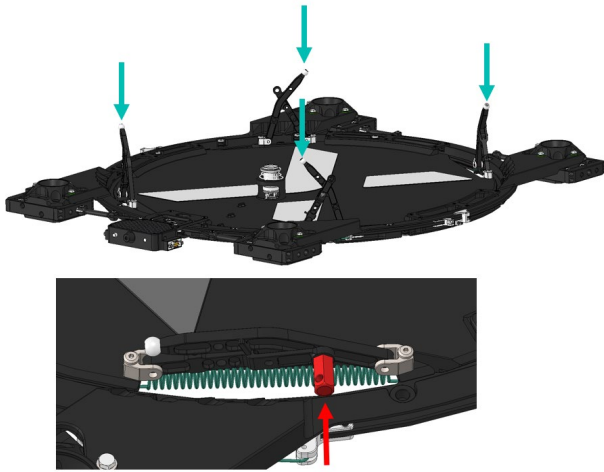
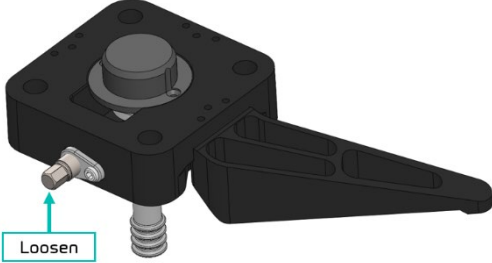
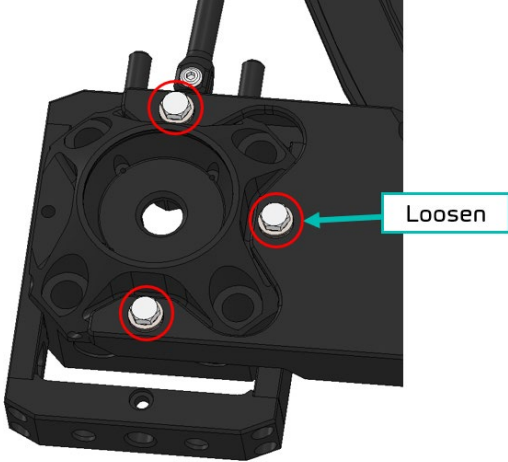
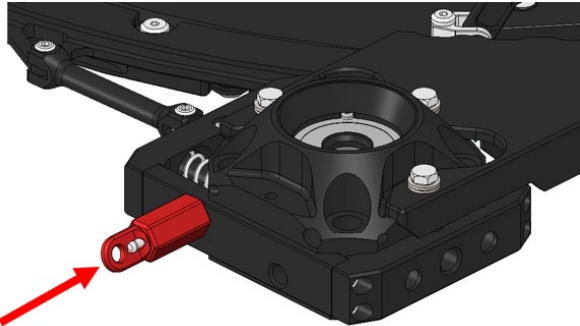
<p>5.</p>	<p>Stow the L-adapter pusher arms by slowly pressing them down simultaneously. Secure each pusher arm with one RBF pin.</p>	
<p>6.</p>	<p>Ensure that the smaller fixation screw (set screw) is loose. Then loosen the preload screws of the S-adapters (four screws total).</p>	
<p>7.</p>	<p>Loosen the three fixation screws holding each HDRM to the Quadro base ring (12 screws total).</p>	
<p>8.</p>	<p>Install one spring-loaded RBF pin to each HDRM.</p>	

3.1.2 Alignment

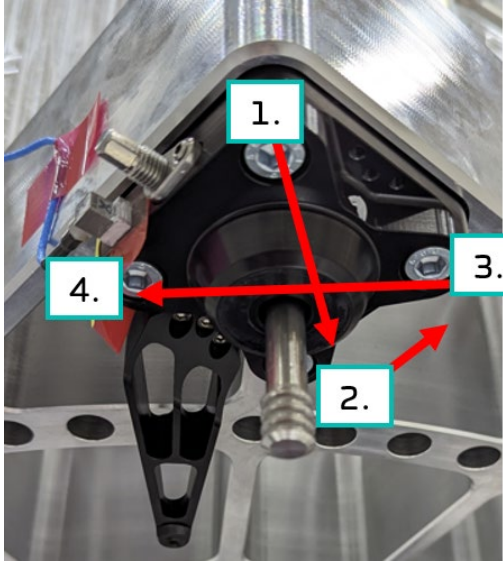
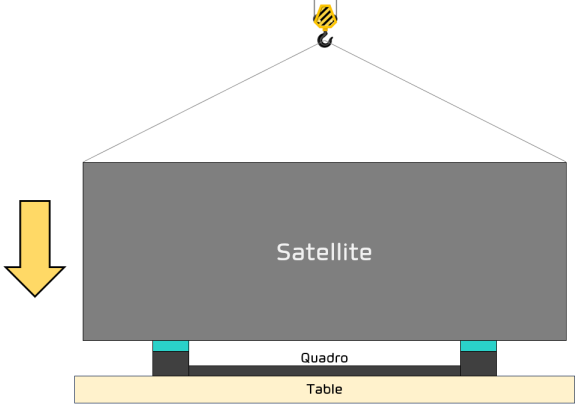
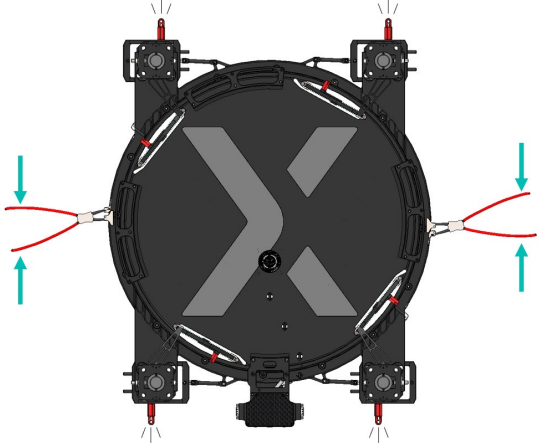
<p>1.</p>	<p>Mount the four S-Adapters to the satellite base plate using M8x25 BUMAX 109 (10.9) screws and NL8ss washers torqued to 30 Nm. Cross pattern for each HDRM (16 screws total).</p>	
<p>2.</p>	<p>Lower the satellite onto the L-adapters. Pay attention to keep the central sep connector aligned.</p>	
<p>3.</p>	<p>Clamp the Quadro system until the HDRM RBF pins click into place.</p>	

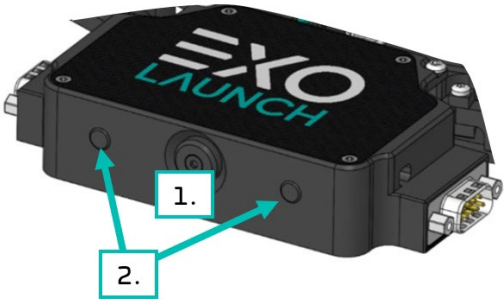
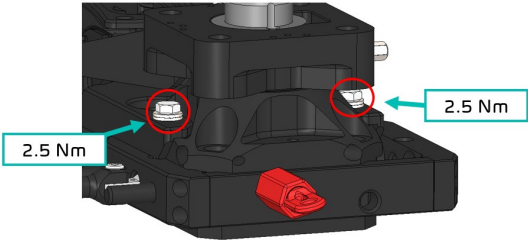
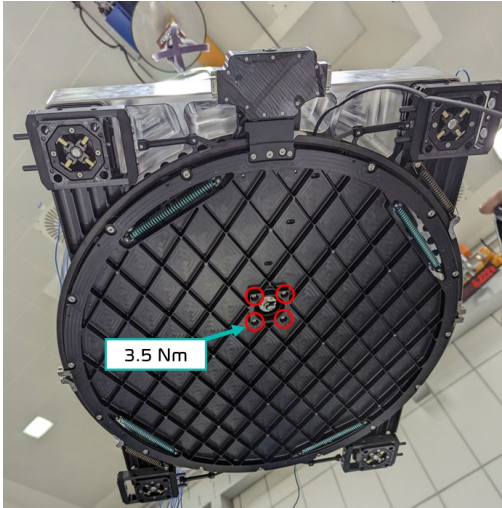
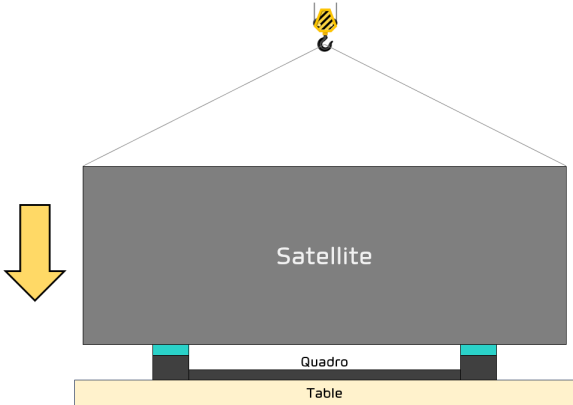
<p>4.</p>	<p>Engage the lock mechanism.</p> <ol style="list-style-type: none"> 1. Push the inhibit pin until it is fully depressed within the housing. 2. Push the lock indicators closed. 	
<p>5.</p>	<p>Fix each HDRM to the L-adapter by tightening the HDRM fixation screws to 2.5 Nm (8 screws total, only 2/3 are accessible for each HDRM).</p>	
<p>6.</p>	<p>Lift the satellite plus Quadro L-adapter to access the separation connector fixation screws from underneath. Torque these screws to 3.5 Nm.</p>	
<p>7.</p>	<p>Lower the satellite back onto the table.</p>	

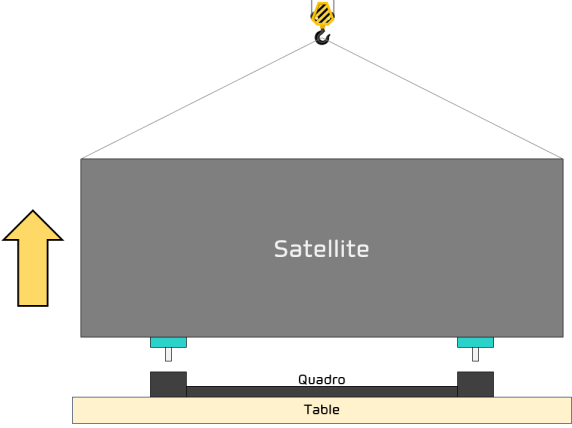
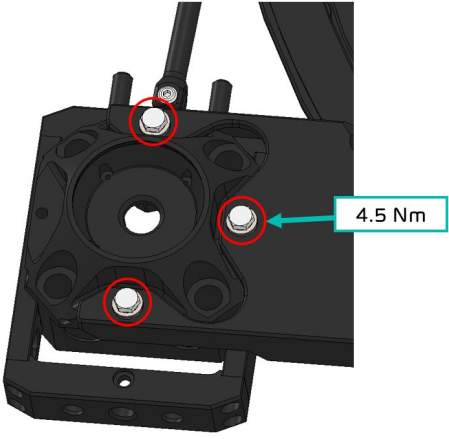

<p>8.</p>	<p>Remove the HDRM RBF pins and release the lock mechanism.</p>	
<p>9.</p>	<p>Lift the satellite.</p>	
<p>10.</p>	<p>Torque all 3 Fixation Screws at each HDRM to 4.5Nm (12 screws total).</p>	

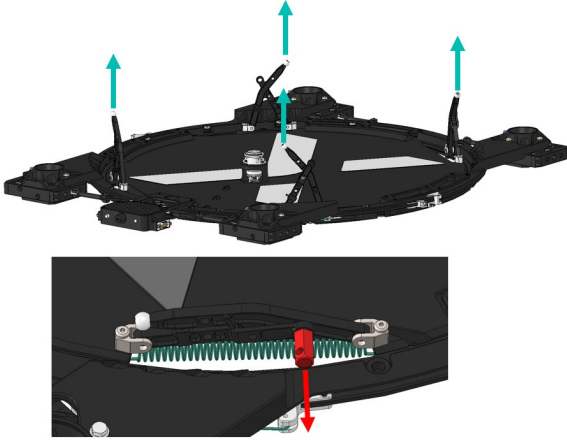
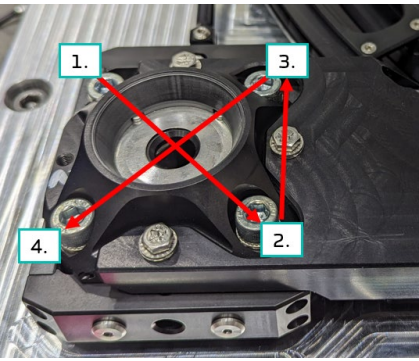
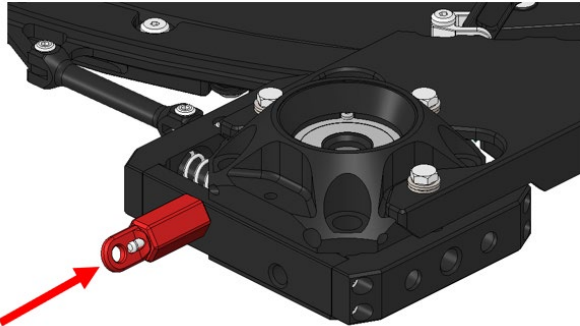
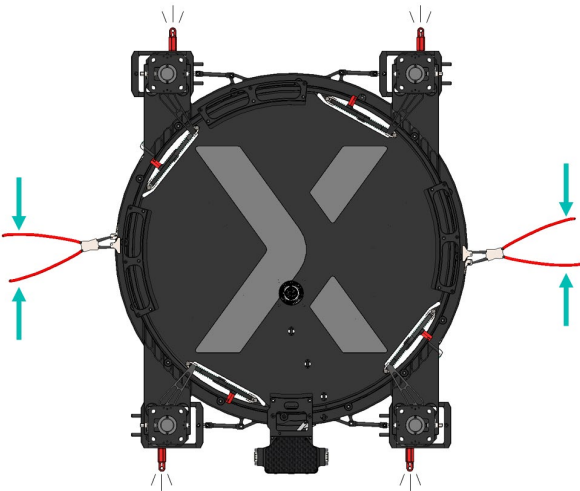
3.1.3 Installation

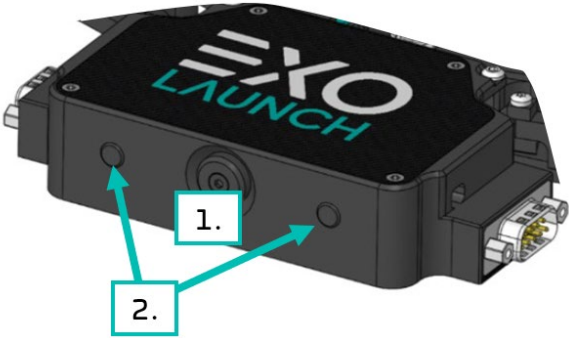
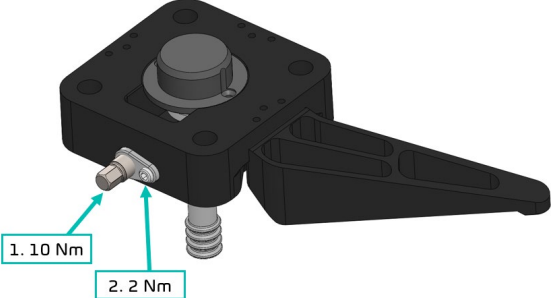
<p>1.</p>	<p>Hold down all 4 pusher arms and remove the RBFs; Slowly release the pusher arms.</p>	
<p>2.</p>	<p>Mate the L-Adapter to the launch vehicle mounting interface with 4x M8x50 [length TBC] and NL8ss washers to 30Nm; Cross-pattern for each HDRM and between HDRM (16 screws total).</p>	
<p>3.</p>	<p>Install one spring-loaded RBF pin to each HDRM.</p>	
<p>4.</p>	<p>Clamp the Quadro system until the HDRM RBF pins click into place.</p>	

<p>5.</p>	<p>Engage the lock mechanism.</p> <ol style="list-style-type: none"> 1. Push the inhibit pin until it is fully depressed within the housing. 2. Push the lock indicators closed. 	 <p>The diagram shows the top and side view of the EXOLAUNCH device. A red arrow labeled '1.' points to a small circular pin on the top surface. Another red arrow labeled '2.' points to a small circular indicator on the side of the device.</p>
<p>6.</p>	<p>For each HDRM:</p> <ol style="list-style-type: none"> 1. Preload the system by torquing the preload screw to 10 Nm. 2. Torque the locking screw to 2 Nm. 	 <p>The diagram shows a close-up of the HDRM assembly. A red arrow labeled '1. 10 Nm' points to a screw on the side of the assembly. Another red arrow labeled '2. 2 Nm' points to a screw on the bottom of the assembly.</p>

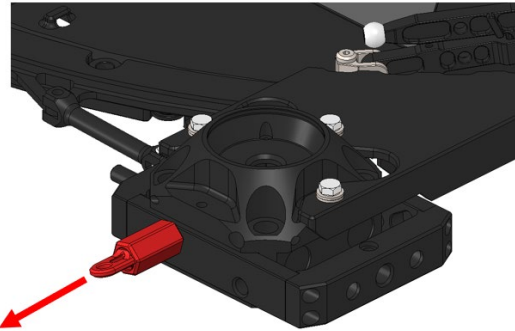
3.1.4 Functional Test and Reset

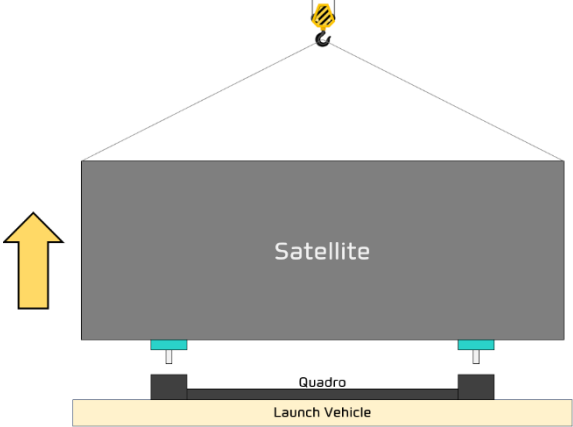
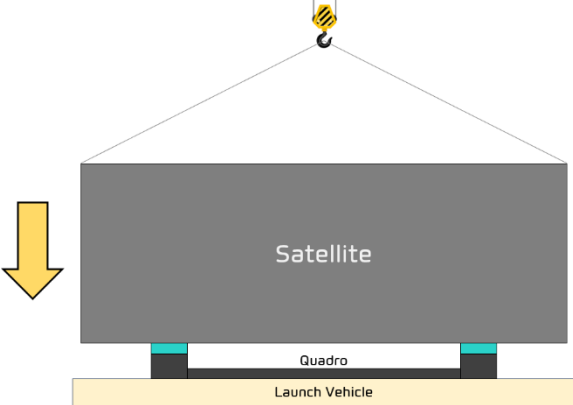
<p>1.</p>	<p>Remove the spring loaded RBFs.</p>	
<p>2.</p>	<p>Release the lock mechanism. Verify that the HDRMs have fully opened, and that the TM1 LED on the handtrigger has toggled.</p>	
<p>3.</p>	<p>Lift the satellite. Verify that the pusher arms fully extend and that the TM2 LED on the handtrigger has toggled.</p>	
<p>4.</p>	<p>Lower the satellite back down onto the L-adapter.</p>	

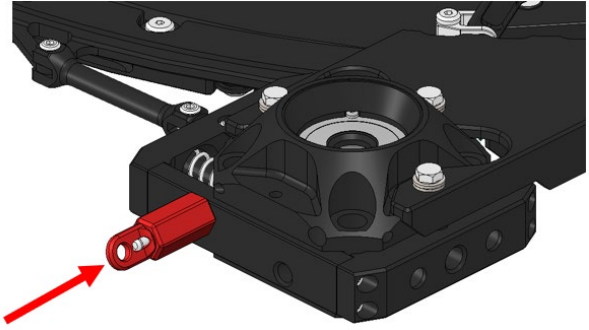
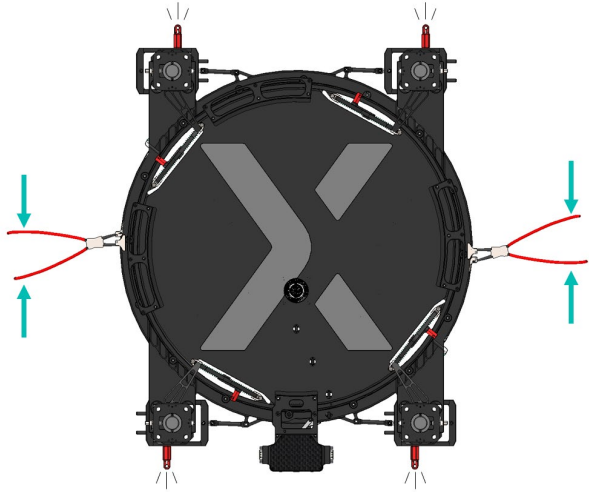
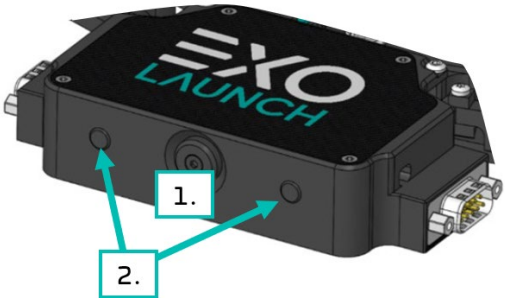
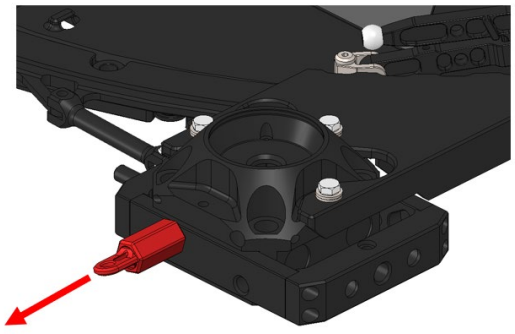
<p>5.</p>	<p>Install one spring-loaded RBF pin to each HDRM.</p>	
<p>6.</p>	<p>Clamp the Quadro system until the HDRM RBF pins click into place.</p>	
<p>7.</p>	<p>Engage the lock mechanism.</p> <p>3. Push the inhibit pin until it is fully depressed within the housing.</p> <p>Push the lock indicators closed.</p>	
<p>8.</p>	<p>Remove all RBF elements.</p>	
<p>9.</p>	<p>Quadro is now ready for flight.</p>	



Appendix

Mechanical Interfaces

A.1. Quadro Arrow 150 Satellite Interface

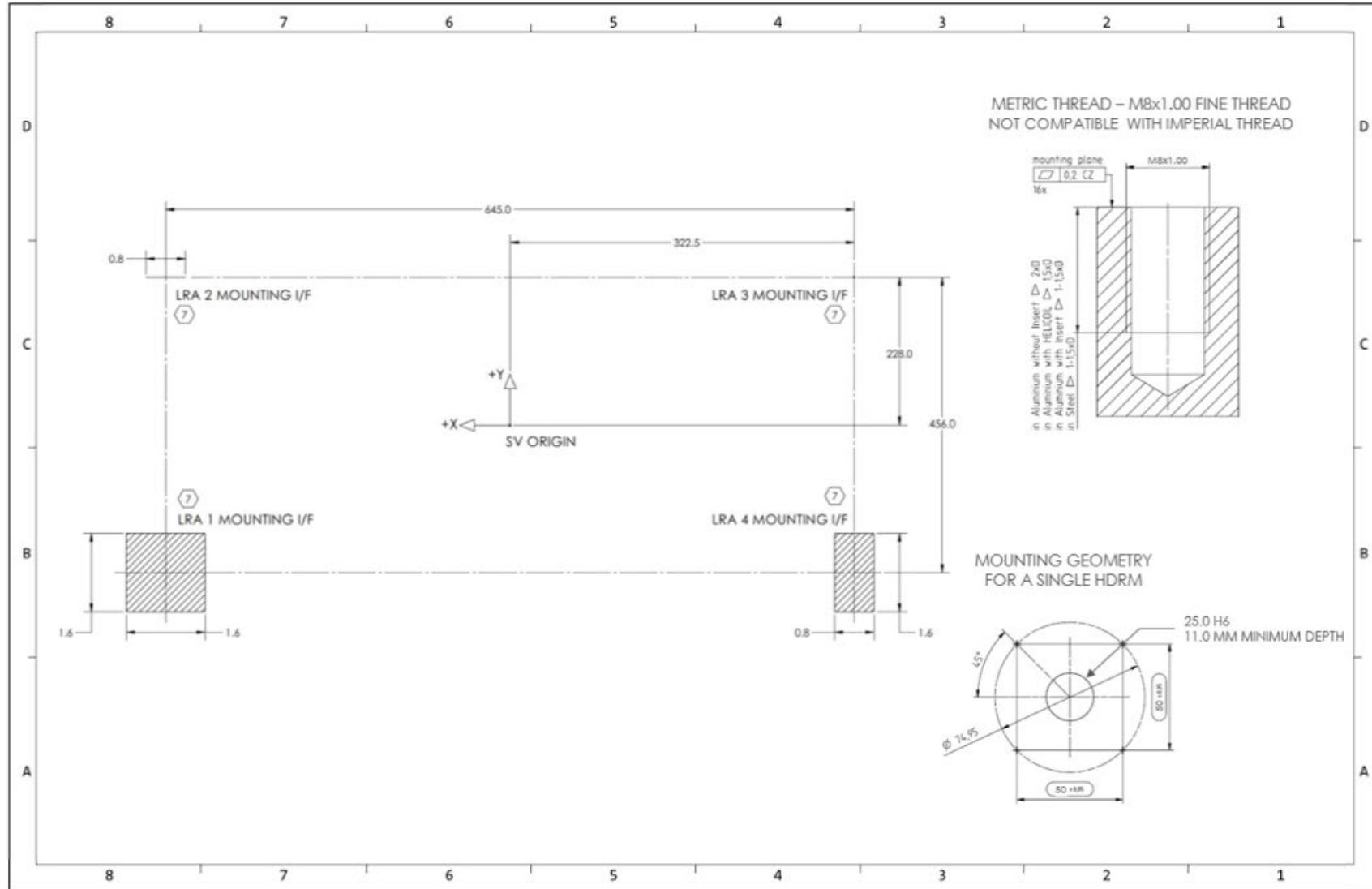

Figure 14: Quadro Arrow 150 Satellite Interface

A.2. Quadro Arrow 150 Launch Vehicle Interface

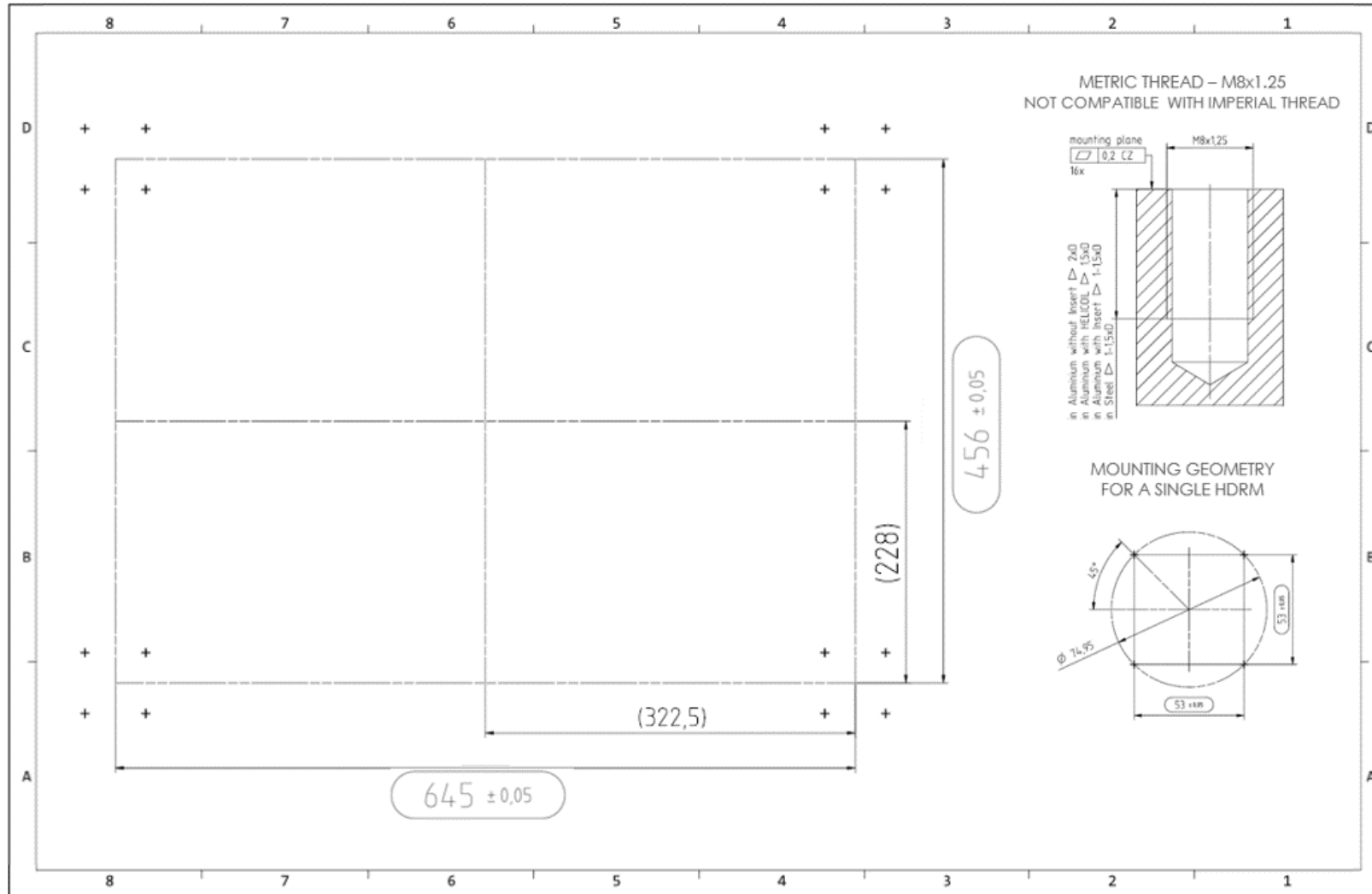

Figure 15: Quadro Arrow 150 Launch Vehicle Interface

